

Device description

- Bluetooth 5.2 Audio and Data Module
- UART/GPIO Command
- 11.8mmx18mmx3.2mm form Factor
- Simultaneous Low Energy and Classic Bluetooth
- Connect to Apps (iOS/Android/etc.)
- Qualcomm Snapdragon Sound (inc. aptX, aptX HD)
- Transmits and receives Bluetooth Audio

Applications

- High-End Audio Visual-Products
- Industrial Data/Audio Applications
- Automotive/Aerospace Applications
- Teleconference Equipment
- POS/Retail Sports/Leisure Equipment

Features



- Audio and High-Speed Data Bluetooth 5.2 Module
- Music Receiver (HFP, A2DP Sink) and Transmitter (AG-HFP, A2DP Source)
- Simultaneous Classic and Low Energy Bluetooth
- Multiple Simultaneous Connections and Profiles
- Profiles: HFP, HSP, AG-HFP, A2DP Sink, A2DP Source, AVRCP, SPP, BLE
- Analog and Digital Audio connection (I2S, PCM)
- Snapdragon Sound (aptX, aptX HD, aptX Adaptive), AAC, Wide Band Speech
- Simple UART or GPIO interface for control
- Integrated Antenna, Small form factor (11.8mm x 18mm x 3.2mm)
- Bluetooth, FCC(US), RED(Europe), MIC(Japan), KCC(Korea) and SRRC(China) certified

Summary

IDC747-1 is ideal for developers who want to quickly and cost effectively integrate high performance Audio and Data Bluetooth functionality into their products. It is controlled through a simple UART interface that also serves for data transmissions. For the Audio, it has Analog or Digital Outputs. The module can connect to multiple devices with multiple profiles. The power consumption is <1mAmp when connected, <1mAmp in Pairing mode and <6mAmp when streaming music at 3.3V. It is supplied FCC, CE and Bluetooth 5.2 certified. It is also supplied with sample Android and iOS Applications to help integrate the Bluetooth functionality with the product end Application. IDC747-1 features can be also customised for specific complex use cases and scenarios. Please contact info@iot747.com for customisation requests.

For additional questions or to submit technical question, go to www.iot747.com or send an email to info@iot747.com.

Contents

General Specifications	3
Footprint	4
Pinout	5
Hardware Design Guidelines	7
Fixed Voltage Supply Configuration	9
Battery Voltage Supply Configuration	10
Module Boot Modes	11
ESD protection	11
GPIOs and UART	12
Audio Interfaces	13
Analogue Audio Inputs	13
Analogue Gain	13
Example Application Schematics	14
Analogue Audio Outputs	16
USB supply configuration:	19
Digital Audio Interfaces	19
I ² S/PCM	19
Solder Reflow Profile	21
Ordering Information	22
Packaging	23
General Notes	24
Change Log	25

General Specifications

No	Pin Name
Bluetooth Standard	Bluetooth 5.2
Interfaces	UART, AIO, GPIO, USB, PCM, I2S, I2C
Size	11.8mm x 18mm x 3.2mm
Weight	1g
Frequency Band	2,402 MHz to 2,480 MHz
Modulation	8 DPSK, PI/4 DQPSK, GFSK
Maximum Data Rate	3Mbps (typical 1.6Mbps)
Operating Range	20m
RF Sensitivity	0.1% BER at -96dBm (Typical)
Transmit Power	Max 13dBm
DAC resolution	16 bits
DAC Out Sample Rate	8 KHz to 90 KHz
DAC SNR	Class D typ: 99.3dBA, Class A-B typ: 100.9 dBA
Stereo Separation	Min: 80dB
Supply Voltage	3.3V to 4.7 V DC (Supports Li Ion battery voltage range)
Typical Current	6mA (Music streaming)
Typical Current Idle	<1mA (Connectable)
Typical Current Discoverable	<1mA (Pairing Mode)
Operating Temperature	-40°C to 85°C
Storage Temperature	-40°C to 105°C

Footprint

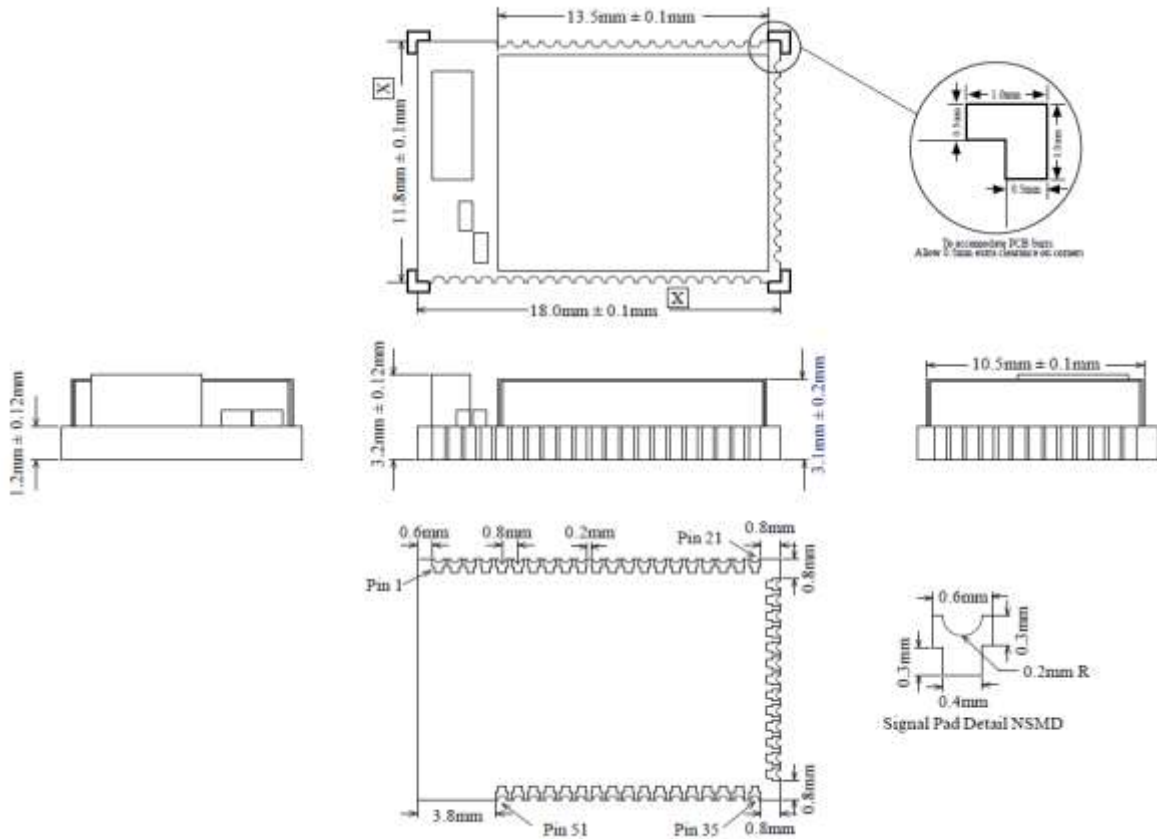

Pinout

No	Pin Name	Pin Type	Pin Description
1	GND	GND	Common Ground
2	GND	GND	Common Ground
3	GND	GND	Common Ground
4	GND	GND	Common Ground
5	PIO_21	Bi-directional	Programmable input/output line
6	PIO_20	Bi-directional	Programmable input/output line
7	PIO_10	Bi-directional	Programmable input/output line
8	PIO_60	Bi-directional	Programmable input/output line
9	PIO_9	Bi-directional	Programmable input/output line
10	PIO_4	Bi-directional	Programmable input/output line
11	GND	GND	Common Ground
12	AIO_1	Bi-directional	Analog programmable input/output line
13	SPKR_LN	Audio output	Speaker output negative, left
14	SPKR_LP	Audio output	Speaker output positive, left
15	SPKR_RN	Audio output	Speaker output negative, right
16	SPKR_RP	Audio output	Speaker output positive, right
17	MIC_BIAS_A	Analog input	Microphone bias
18	MIC_RN	Analog input	Microphone input negative, right
19	MIC_RP	Analog input	Microphone input positive, right
20	MIC_LN	Analog input	Microphone input negative, left
21	MIC_LP	Analog input	Microphone input positive, left
22	GND	GND	Common Ground
23	PIO_3	Bi-directional	Programmable input/output line
24	PIO_8	Bi-directional	Programmable input/output line
25	PIO_7	Bi-directional	Programmable input/output line
26	PIO_5	Bi-directional	Programmable input/output line
27	GND	GND	Common Ground
28	SYS_CTRL	Digital input	Take High to Boot Device
29	CHG_EXT	Charger input	External battery charger control
30	VCHG	Charger input	Battery Charger Input
31	VBAT_SENSE	Battery sense	Battery Charger Sense
32	VBAT	Battery terminal +ve	Battery Positive
33	VDD_PADS	Supply	Positive Supply input
34	VCHG_SENSE	Supply	Charger input sense pin
35	USB_N	Bi-directional	USB data negative
36	USB_P	Bi-directional	USB data positive
37	LED_2/AIO_2	Bi-directional	LED Open Drain Driver / Analog/Digital Input
38	LED_4/AIO_4	Bi-directional	LED Open Drain Driver / Analog/Digital Input
39	LED_5/AIO_5	Bi-directional	LED Open Drain Driver / Analog/Digital Input
40	UART_CTS	Bi-directional	UART Clear to Send
41	UART_TX	Bi-directional	UART TX Data

No	Pin Name	Pin Type	Pin Description
42	UART_RX	Bi-directional	UART RX Data
43	UART_RTS	Bi-directional	UART request to send ,active low
44	RST#	Reset Input with Pull-Up	Reset if low for more than 5ms
45	LED_0/AIO_0	Bi-directional	LED Open Drain Driver / Analog/Digital Input
46	PCM_SYNC/I2S-WS	Bi-directional	Synchronous data sync
47	PCM_CLK-I2S-SCK	Bi-directional	Synchronous data clock
48	PCM_OUT-I2S-OUT	CMOS output	Synchronous data output
49	PCM_IN-I2S-IN	CMOS input	Synchronous data input
50	PIO_2	Bi-directional	Programmable input/output line
51	PIO_6	Bi-directional	Programmable input/output line

Notes:

PIO_X are bidirectional with weak pull down

Reset Input is with strong pull-up

USB data positive with selectable internal 1.5kΩ pull up resistor

UART are Bidirectional with weak pull up

Hardware Design Guidelines

Antenna Placement Considerations

The IDC747 requires specific layout conditions to achieve the maximum range from the onboard Antenna. The module is designed to be placed in the top right-hand corner or edge of an application board, ideally butted up to the edge of the board to allow for maximum free space radiation from the antenna. Orientate the front of the module to face the direction that you want the maximum range for your product.

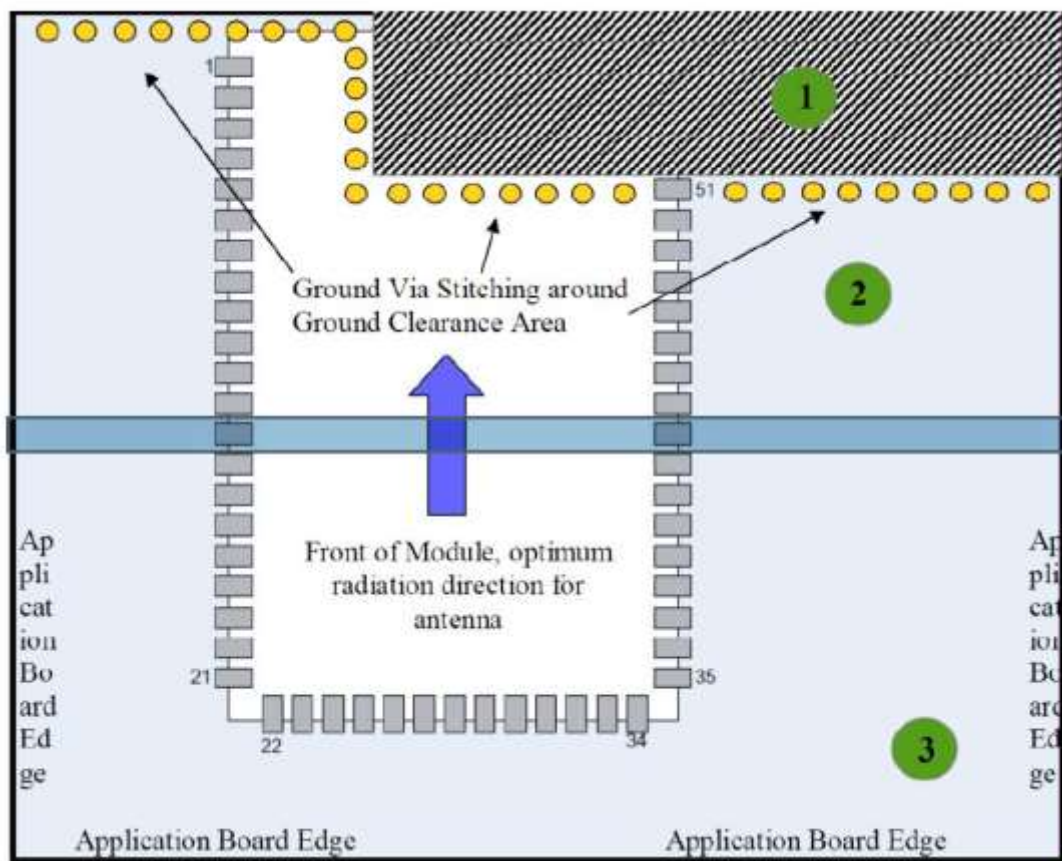

1. The ground clearance area is dimensioned below. All copper on all layers should be removed from this area up to the application board edges on the top and right-hand side of the board. No metallic components can be placed in this area. If your application is to be housed in a case only use plastic or rubber materials and avoid any metallic coatings in this area. Avoid routing any signal or power tracks in this area.
2. Ground fill should be used where ever possible on the application board, tie all ground fill areas on multiple layers together with through ground via stitching.
3. The performance of the antenna depends on ground fill area and board size, small boards with smaller ground areas may not perform as well as larger boards with large ground areas.

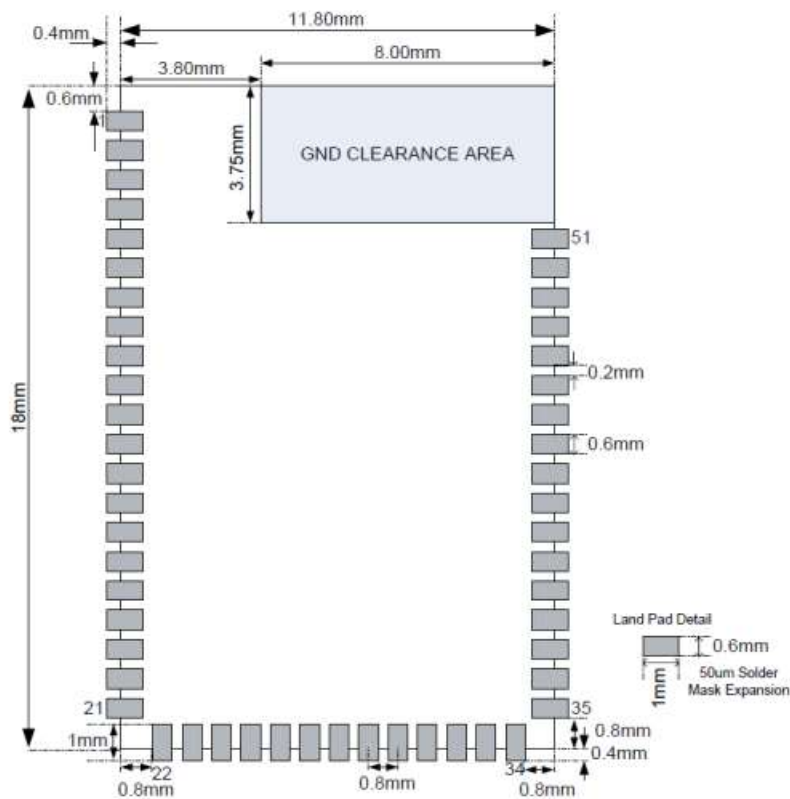
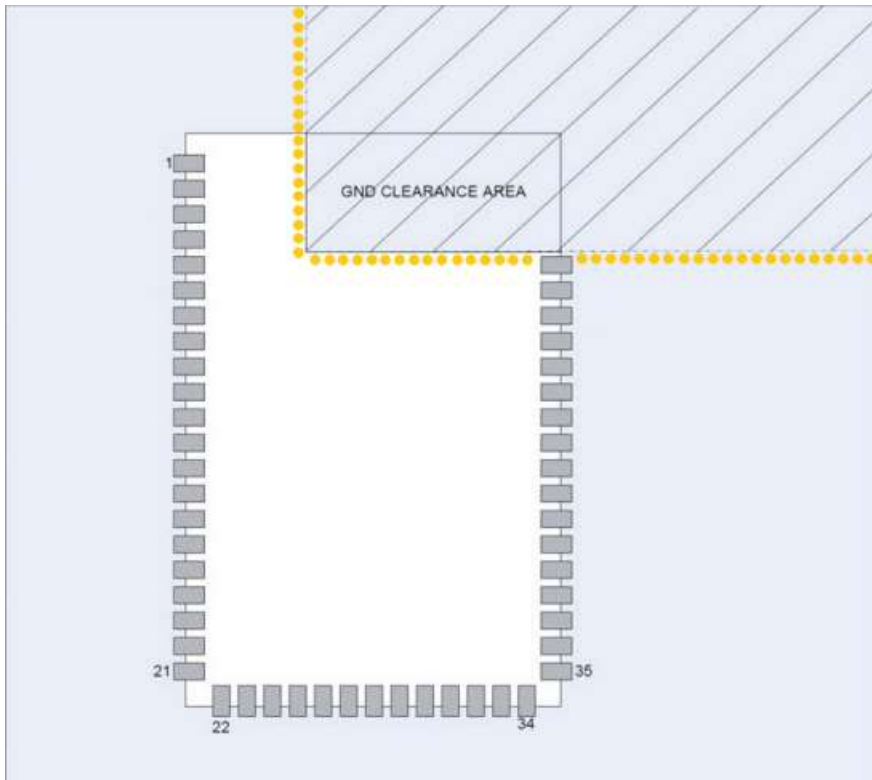

Supply Configuration

The IDC747 is typically powered by a fixed 3V supply where the module is included in a larger portable device and charging of the battery is supported by alternative functionality outside the remit of the IDC747. This is the Fixed Voltage Supply Configuration.

Alternatively, for portable applications, the module supports an internal charger function where no extra external components are required for charging operation. In this case, the main power is supplied by a battery, typically a Li Po cell with a nominal 3.1-3.3V supply. A 5V charger input, typically supplied by a USB source, is used to charge the battery. The IDC747 integrated Li-Ion charger is designed to support single Li-Ion cells with a wide range of cell capacities and variable V_{FLOAT} voltages. It supports charge rates of 2mA to 200mA with no additional external components required. This is the Battery Voltage Supply Configuration.

Fixed Voltage Supply Configuration

For a single supply application as part of a larger portable application circuit, a regulated voltage can be used to power the IDC747 directly. There is no direct battery connection and the IDC747 is not used to charge the battery.

In this fixed voltage configuration, the pins VBAT, VBAT_SENSE and VDD_PADS are all connected to a single supply voltage rail. VCHG and VCHG_SENSE and CHG_EXT are left unconnected as per the figure below. Alternatively, we recommend connecting them to test points if possible. Test points can help debug and testing in some cases prior to production.

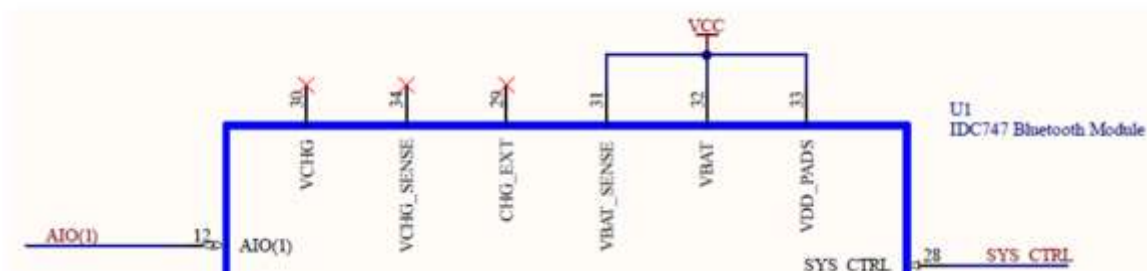

Pin #	Pin Name	Connection	Voltage Input Range
29	CHG_EXT	Not Connected/Test Point	NA
30	VCHG	Not Connected/Test Point	NA
31	VBAT_SENSE	Connect to 3.3V Supply	3.0V** to 4.6V
32	VBAT	Connect to 3.3V Supply	3.0V** to 4.6V
33	VDD_PADS	Connect to 3.3V Supply	1.7V to 3.6V
34	VCHG_SENSE	Not Connected/Test Point	NA

** Devices operates down to 2.8V recommended software shut off is at 3.0V

Battery Voltage Supply Configuration

In a battery sourced application VBAT and VBAT_SENSE are connected to the battery source, VDD_PADS is driven from a regulated supply external to the module, VCHG and VCHG_SENSE are connected to the charging input source as per the figure below.

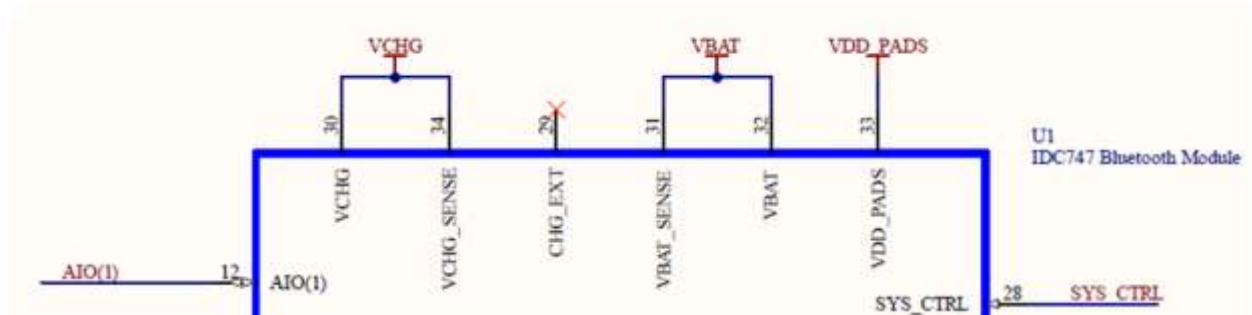

Pin #	Pin Name	Connection	Voltage Input Range
29	CHG_EXT	Not Connected	
30	VCHG	Charger Source (VBUS)	4.75V* to 6.5V
31	VBAT_SENSE	Connect to Battery	3.0V** to 4.6V
32	VBAT	Connect to Battery	3.0V** to 4.6V
33	VDD_PADS	Connect to regulated 3.3V Supply	1.7V to 3.6V
34	VCHG_SENSE	Charger Source (VBUS)	NA

* Can operate at a reduced capacity down to 4.0V, VCHG minimum is 4.0V

** Devices operates down to 2.8V recommended software shut off is at 3.0V

VDD_PADS is generated by a fixed voltage regulator in this configuration to provide a constant voltage reference for the IO supply domain. When connected to a battery a buck/boost synchronous regulator is recommended, the circuit below provides an example.

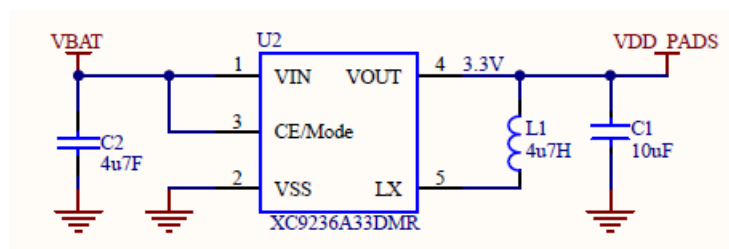

To save the cost of an external regulator the VDD_PADS input can be connected direct to the battery input as long as all digital peripherals are tolerant of the variation of the battery voltage over its entire operating range of 2.8V to 4.24V (VFloatmax).

Module Boot Modes

If the device is 'No Power' state (No voltage applied to the module), a connection (voltage applied) to VBAT or VCHG will transition the module from unpowered to Active.

The device can also be in 'Power Off' State while there is voltage applied to VBAT. The 'Power Off' state is different to the No Power state because the IDC747 has voltage on VBAT. In the 'Power Off' state the following events boot the chip and transition it to the Active state: (1) a rising edge on SYS_CTRL held high for 20 ms or (2) a rising edge on VCHG held high for 20 ms. NOTE that the device cannot be in 'Power Off' when voltage is present on VCHG input. The device can transition from Active to 'Power Off' with a UART command (See UART Manual) or a rising edge on SYS_CTRL.

Depending on the software configuration SYS_CTRL can be used to boot the module or wake from a dormant or sleep state. An example application below shows the SYS_CTRL driven by a push button connected to the VBAT supply, pressing the button connects the source voltage via the resistor divider network to the SYS_CTRL input enabling the device. Please refer to the UART Command Manual for the SYS_CTRL function once the module is booted.

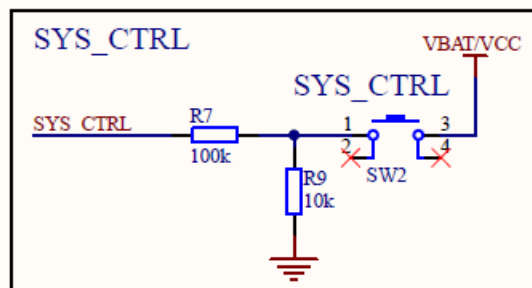

To Wake-Up an external processor on Connection, PIOs can be used. With GPIO control disabled, PIOs will go High when a Bluetooth connection is established. Please refer to the UART command line manual for more details.

ESD protection

The module has no supplementary ESD protection other than that provided by the IC within the module. The Bluetooth IC ESD protection is limited to:

Human Body Model Contact Discharge per ANSI/ESDA/JEDEC JS-001
Class 2 - 2kV (all pins except CHG_EXT; CHG_EXT rated at 1kV)

Machine Model Contact Discharge per JEDEC/EIA JESD22-A115
200V (all pins)

Charged Device Model Contact Discharge per JEDEC/EIA JESD22-C101
Class II - 200V (all pins)

It is recommended to adding supplementary ESD protection to externally available interfaces in the end application.

GPIOs and UART

The module is controlled by GPIOs. This can be configured. If GPIO control is not used, these GPIOs should be left floating. The UART by default does not use RTS/CTS flow control. If the users do not expect to use it, these lines should be left floating.

Digital Pin States on RESET or after Power Up

The following table shows the Digital Pin States on RESET or after power up.

Pin Name / Group	I/O Type	State after PowerUp/RESET
USB_DP	Digital bi-directional	N/A
USB_DN	Digital bi-directional	N/A
UART_RX	Digital bi-directional with PU	Strong PU
UART_TX	Digital bi-directional with PU	Weak PU
UART_CTS	Digital bi-directional with PD	Weak PD
UART_RTS	Digital bi-directional with PU	Weak PU
PCM_IN	Digital bi-directional with PD	Weak PD
PCM_OUT	Digital bi-directional with PD	Weak PD
PCM_SYNC	Digital bi-directional with PD	Weak PD
PCM_CLK	Digital bi-directional with PD	Weak PD
RST#	Digital input with PU	Strong PU
PIO_X	Digital bi-directional with PD	Weak PD

PD = Pull Down, PU = Pull Up

Input and Tri-state Currents	Min	Typ	Max	Unit
Strong pull-up	-150	-40	-10	μA
Strong pull-down	10	40	150	μA
Weak pull-up	-5	-1.0	-0.33	μA
Weak pull-down	0.33	1.0	5.0	μA

Audio Interfaces

IDC747 supports high quality analogue and digital audio interfaces supported by an audio application processor, high performance analogue and digital audio codecs driving Class-AB and Class-D headphone drivers.

Analogue Audio Inputs

IDC747's analogue input pins support mono, stereo and line-in, single ended and differential input configurations. The internal High Quality 24bit ADCs support a maximum input voltage of 2.4V (at 0dB gain) and provides over 60dBs of digital and analogue gain with a minimum 80dB of stereo separation (crosstalk). An integrated microphone bias driver with a tuneable bias voltage range from 1.5V to 2.1V delivers up to 3mA of bias current with a typical output noise of 5uVrms suitable for driving most Electret and MEMS microphones.

The analogue audio input is configured via the software API and supports 4 standard modes

Dual differential

Dual single-ended noninverted (positive inputs)

Dual single-ended inverted (negative inputs)

Single differential

Or each input can be configured individually for differential or single ended microphone or line-in input configuration. Analogue audio inputs should be AC coupled with a minimum of 2.2uF capacitor, capacitor values below this degrade the low frequency response.

Analogue Gain

An internal pre-amplifier prior to the HQADC provides a 0-39dB of programmable gain in 3dB steps. At 0dB gain the preamplifier maximum input voltage swing is 2.4V as the gain increases the input voltage swing must reduce to avoid compressing the ADC. The table below shows the maximum recommended analogue input voltage swing vs analogue preamplifier gain settings.

Analogue Gain	Input Impedance (kΩ)	Input amplitude (mVpk-pk)
0	20	2400
3	20	1699
6	20	1203
9	20	852
12	20	603
15	20	427
18	20	302
21	20	214
24	20	151

27	10	107
30	10	76
33	10	54
36	10	38
39	10	27

For line-in input applications a gain of 0dB is recommended

Example Application Schematics

IDC747 Analogue Audio Nets

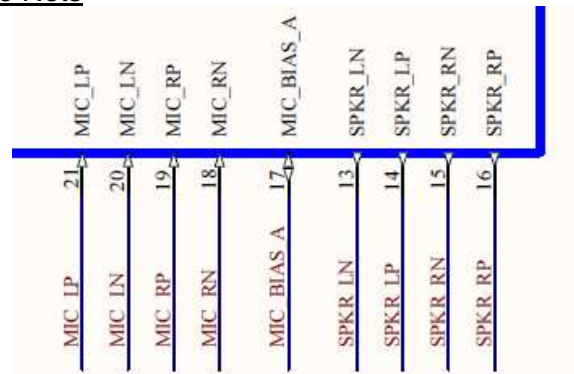

All analogue inputs are DC coupled and must be externally ac coupled for correct operation.

Stereo Line In

A single 4-pole audio jack provides L and R audio channels:

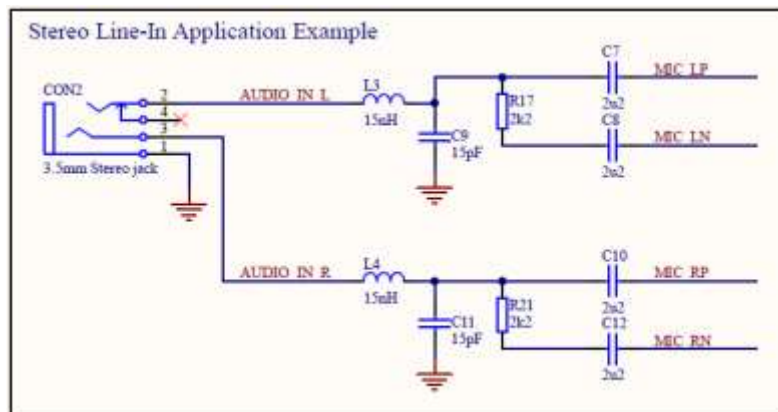

Mono Line In

Two 2-pole audio jacks providing independent audio channels

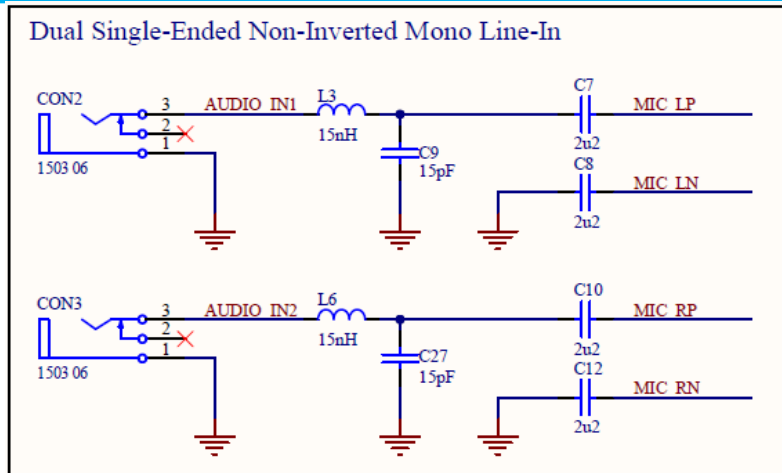

One 2-pole audio jack providing single mono audio source, unused inputs are AC grounded

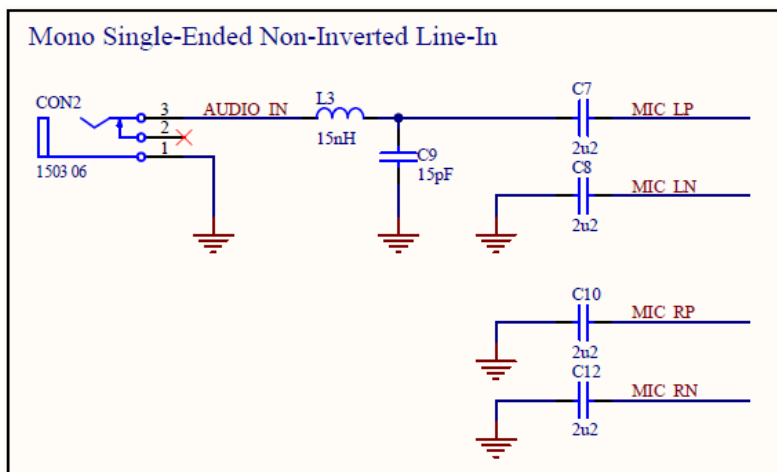

Microphone Input

Dual Microphones

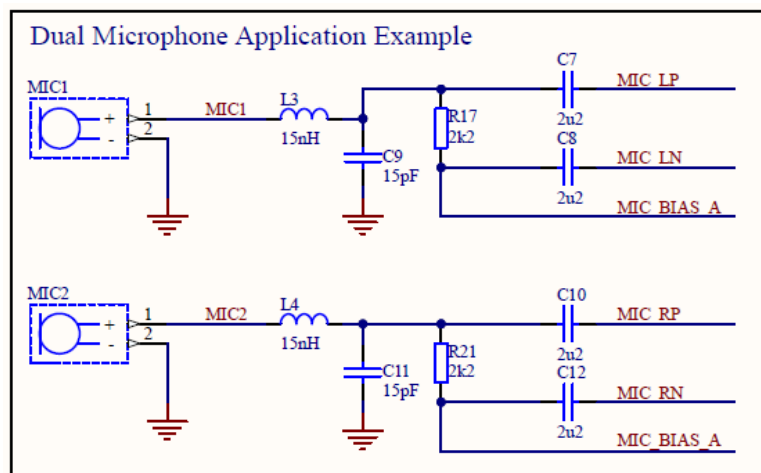

Some microphones may require a higher load capacitance, in which case a maximum 2.2uF capacitor can be added across MIC_BIAS with a 10R value resistor inserted between the MIC_BIAS_A and the microphone as below:

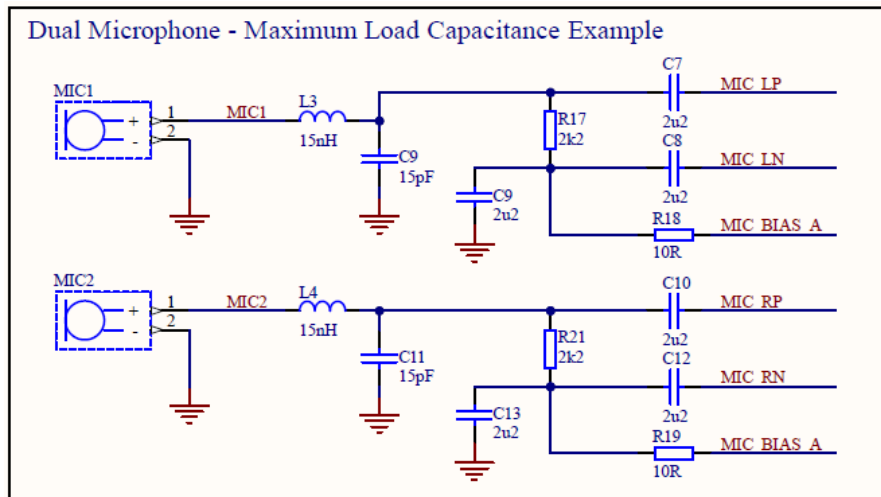

If a single microphone is used, the unused analogue inputs should be AC coupled to ground.

MEMS Microphone

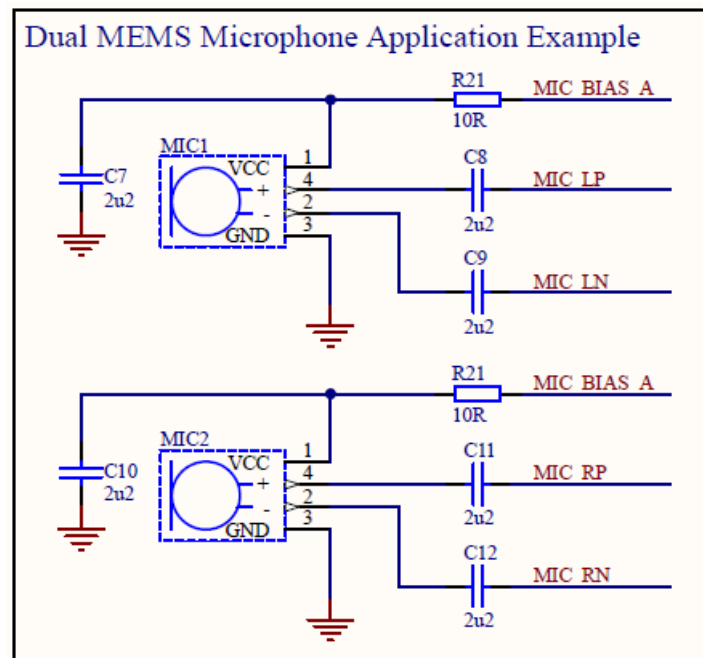

If a single microphone is used, the unused analogue inputs should be AC coupled to ground.

Analogue Audio Outputs

The IDC747's Class-D and Class-AB headset/speaker outputs are stereo differential outputs capable of directly driving 30 mWrms into 32 Ω or 16 Ω speaker loads. Class-D operation enables reduced power consumption, ideal for headset applications, its 3-state BD modulation enables a filter-free configuration, where most of the analogue driver is powered down, supports differential headphone loads of 16 Ω/32 Ω.

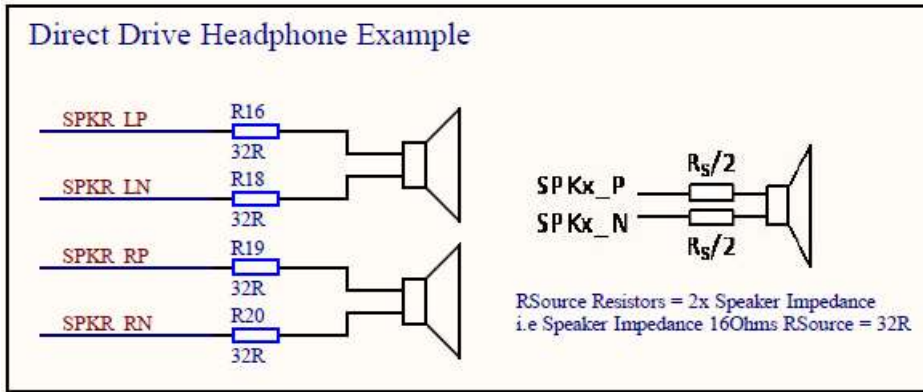

To achieve optimal audio performance in direct drive applications the DACs should operate at close the maximum output voltage of 1Vrms. This can be achieved by adding source resistors between the output terminals and the speaker driver, the value of which are double the rated speaker impedance. i.e., for 16Ω speakers use 32Ω resistors, for 32Ω speakers use 64Ω resistors.

Class-AB operation enables either headphone or speaker applications, with higher impedance loads such as differential line out or for driving an external power amplifier. For such applications requiring external power amplifiers, the output should be filtered using a 30 kHz RC low pass filters as shown in the application schematic below:

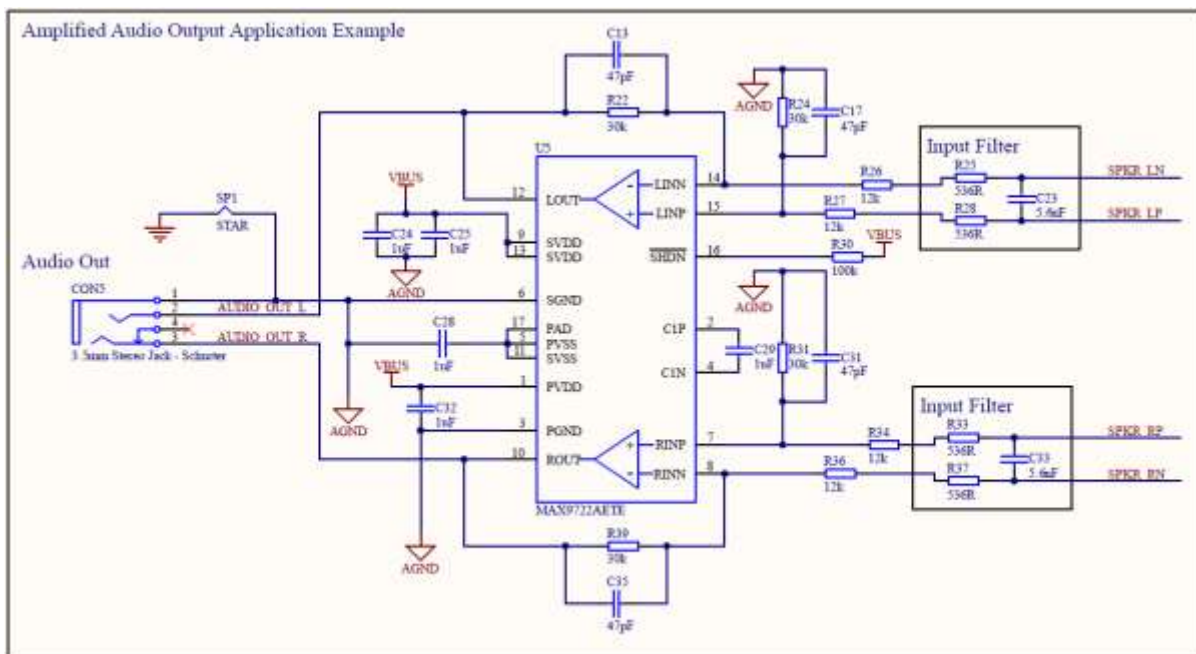

Further noise shaping can be employed by the addition of a DC blocking capacitor between the input filter and the input resistor of the audio amplifier. This forms a high pass filter which has a 3dB cut-off frequency described by the equation below.

$$f_{3dB} = \frac{1}{2\pi R_{IN} C_{IN}}$$

The recommended layout for the analogue audio outputs is to use differential routing, keeping the two channels isolated from each other and from other sensitive circuitry.

The IDC747 DK1 board uses an external audio amplifier for audio application demonstration purposes. When using an external audio amplifier, it is important to follow the manufacturers recommended circuit and layout guidelines to achieve the best possible audio experience. Always use a high-quality audio amplifier ideally with click and pop suppression circuits built in. These amplifiers use noise suppression and soft start techniques to filter supply noise and transients as well as minimising ground loop currents and DC offsets that can cause degraded audio effects. Some amplifiers even employ ground sensing and suppression techniques to minimise and remove noise coupling to the audio path.

In the example amplifier circuit shown above the amplifier audio ground is connected to the main ground via a single “star” point at the audio output jack. This is suitable for connection to headphones where noise from external sources are not expected.

When connecting to external devices such as laptops in a “Line In” configuration there is a possibility that the sleeve of the audio cable can carry noise derived from the laptop. Also external devices connected through the audio cable sleeve can have different ground potentials which causes currents to flow through the sleeve ground. In this case it is important to isolate the sleeve ground from the audio amplifier to avoid the noise coupling to the amplifier and degrading the signal source. In this case add a filter circuit or ferrite bead connecting the sleeve ground to the ground on the application board as shown below.

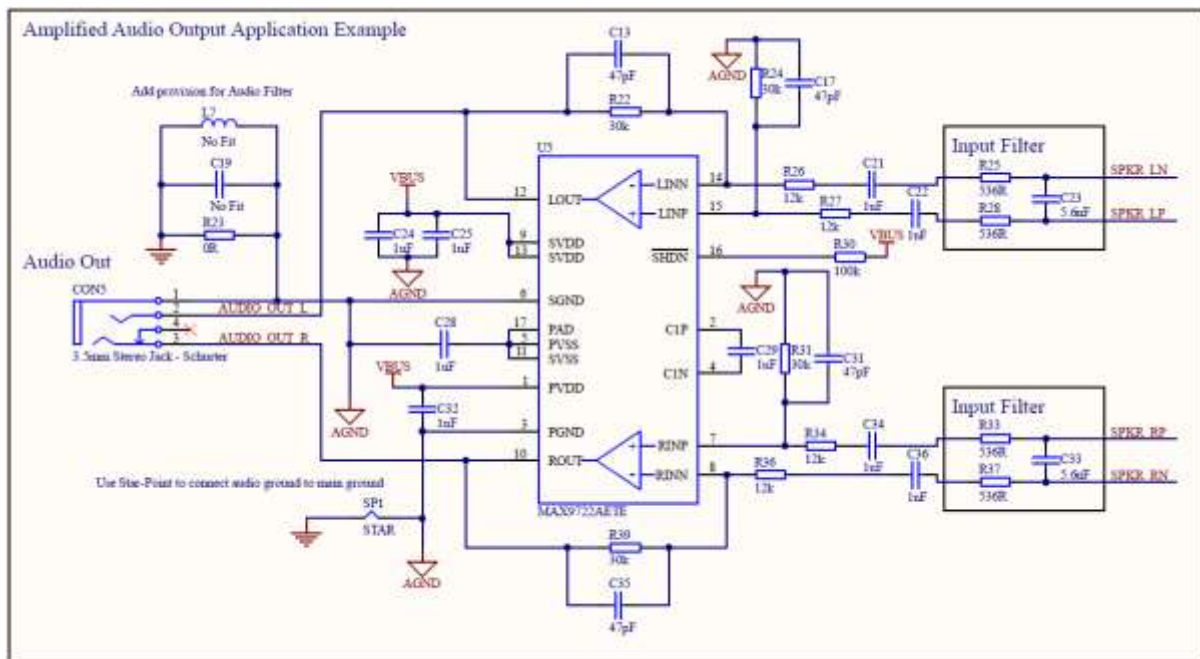

Some amplifiers do not support “capless” operation and require ac coupling on the input and output of the amplifier. Series capacitance can introduce clicks and pops during turn off and turn on as voltage transients occur across the capacitors causing audible spikes on the audio output.

Choice of capacitors used in these configurations is important, avoid using ceramic capacitors as these tend to have high voltage coefficients. Use low voltage coefficients capacitors such as tantalum or electrolytic capacitors to reduce low frequency distortion effects.

In differential mode the tolerance of the source and feedback resistors which set the gain of an amplifier is important. 1% resistors give a 40dB CMRR (Common Mode Rejection Ratio) whereas 0.1% resistors give a 60dB CMRR. Use 0.1% resistors where possible.

USB supply configuration:

In many applications supply noise can significantly degrade audio performance. This is especially true in USB powered applications or where a USB source is used to charge a battery powered application. USB sources have varying noise levels and in addition to steady state noise levels, the plugging and unplugging of USB chargers can cause large supply transients that ripple through the power supply chain to cause clicking and popping in the audio domain. It is recommended to follow good noise immunity pcb design practices, ground isolation, short residual current return paths and the use of ferrite bead and large decoupling capacitors on USB supply connections.

An example USB supply configuration is shown below.

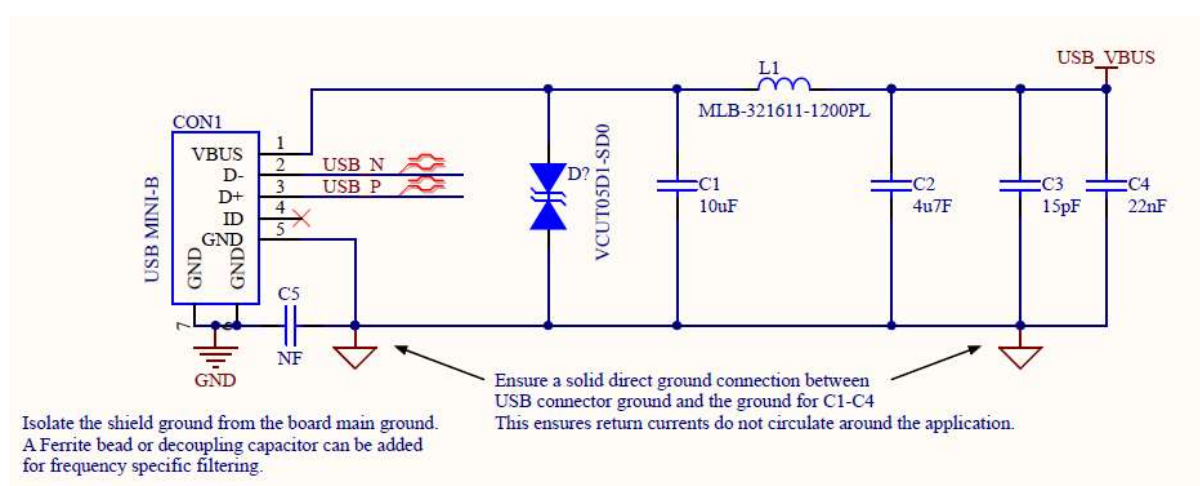

Digital Audio Interfaces

The IDC747 supports digital microphones as inputs, and interfaces to external audio devices via a standard I2S/PCM interface. Up to eight channels of digital microphone inputs are supported. These are grouped as four pairs, as most digital microphones support a L/R selection pin which allows for the clocking of two microphones from the same clock, with one being sampled on the rising clock edge and the other on the falling clock edge

Eight digital microphone clock frequencies can be generated. Configurable at: 500 kHz, 571 kHz, 666 kHz, 800 kHz, 1 MHz, 1.33 MHz, 2 MHz, and 4 MHz clock frequencies.

The digital microphone, CLK and Data functions can be mapped to any PIO on the module.

I2S/PCM

IDC747 provides a standard I2S/PCM interface capable of operating at up to a 384 kHz sample rate. The I2S/PCM port is highly configurable with alternate PCM modes, and has the following options:

- SYNC edge position selectable to align with start of channel data (PCM mode), or 1 clock before start of channel

- data (I²S mode)
 - Master (generate CLK and SYNC) or Slave (receive CLK and SYNC) (PCM/I²S)
 - SYNC polarity (PCM)
 - Long or short SYNC (PCM)
 - Left or right justification (PCM/I²S)
 - Sign extension / zero pad (PCM)
 - Optional tri-state at end of word (PCM)
 - Optional invert of clock (PCM/ I²S)
 - 13/16/24-bit per sample (PCM/ I²S)
 - Up to four slots per frame (PCM)

The I²S/PCM interface is available on dedicated pins 47-49 see the Pin Out table on pages 5 and 6 for details. A Master Clock (MCLK) function for synchronising external devices is not supported on IDC747.

Solder Reflow Profile

The solder profile is described below.

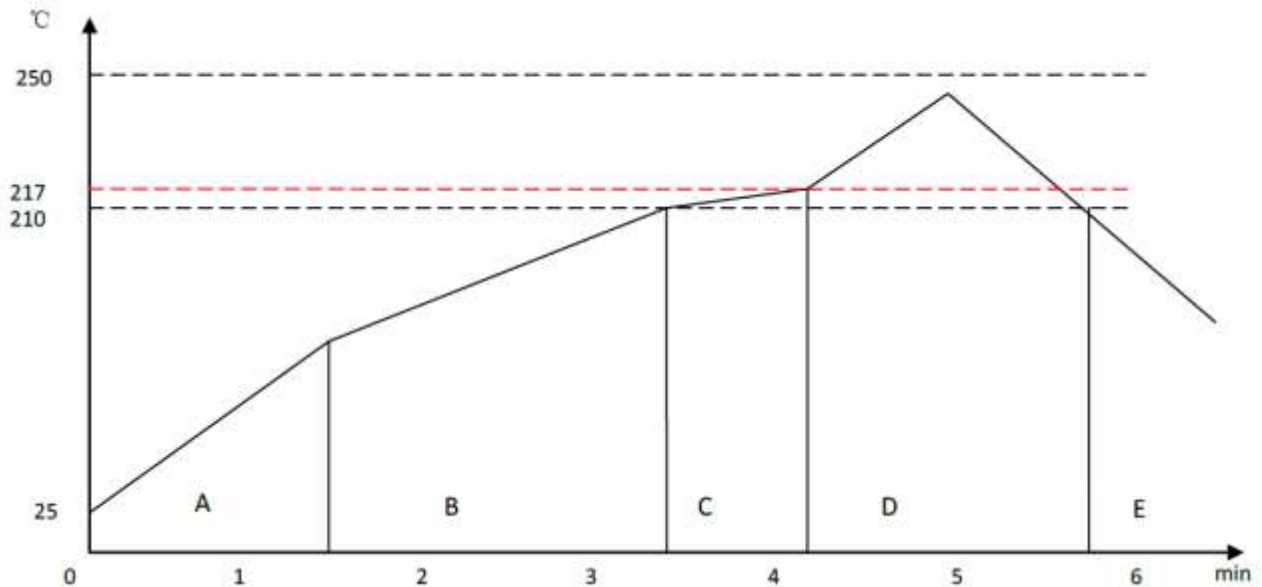

Zone A: Preheat: This raises the temperature at a controlled rate, typically 0.5 - 2C/s. This will preheat the component to 120°C to 150°C to distribute the heat uniformly to the PCB.

Zone B: Equilibrium1: In this zone, the flux becomes soft and uniformly spreads solder particles over the PCB board, preventing re-oxidisation. The recommended temperature for this zone is 150°C to 200°C for 60s to 120s.

Zone C: Equilibrium2: This is optional and in order to resolve the upright component issue. Temperature is 210°C to 217°C for 20s to 30s.

Zone D: Reflow zone: The temperature should be high enough to avoid wetting but low enough to avoid component deterioration. The recommended peak temperature is 230°C to 250°C. The soldering time should be 30s to 90s when the temperature is above 217°C.

Zone E: Cooling: The cooling rate should be fast to keep the solder grains small which will give a longer lasting joint. A typical cooling rate is 4°C/s.

Ordering Information

Order Number	Description
IDC747-1	Bluetooth Module
IDC747-1-DK	IDC747 Development board

Modules are shipped Flashed with the latest AudioAgent firmware production build. Customers need to confirm at order with distributors that they will receive the firmware build they require. For volume orders (1k quantities), modules can be shipped flashed with custom firmware. Please inquire with info@iot747.com for more information.

Packaging

Modules are shipped in a Tape and Reel. The package and inside tape and reel dimensions are shown below:

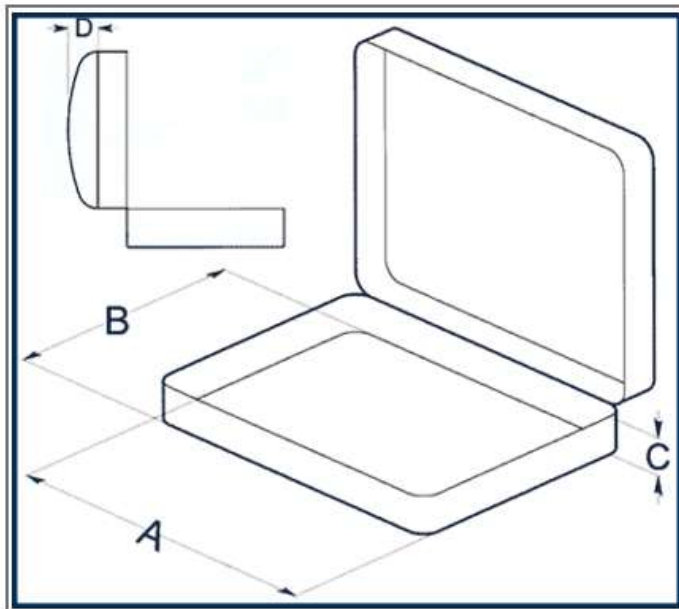

- A= 380mm
- B=380mm
- C=85mm
- D=0mm

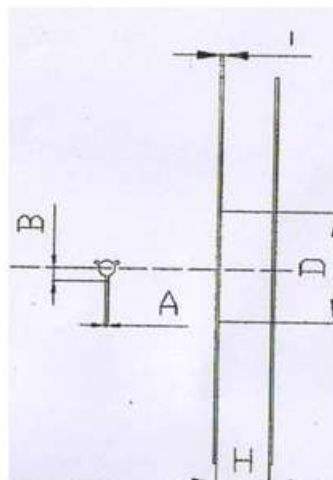
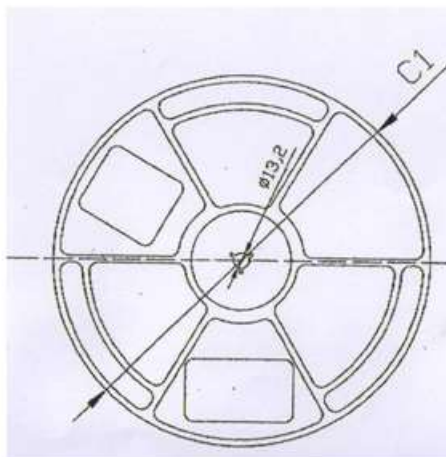

- C1= 330mm
- A=2.5mm
- B=11mm
- H=56.8mm
- I=2.25mm
- D=99.5mm

General Notes

IOT747 products are not authorised for use in life-support or safety-critical applications. Use in such applications is done at the sole discretion of the customer. IOT747 will not warrant the use of its devices in such applications.

While every care has been taken to ensure the accuracy of the contents of this document, IOT747 cannot accept responsibility for any errors. IOT747 reserves the right to make modifications, corrections and any other changes to its products at any time. Customers should obtain the latest information before placing orders.

IOT747 other products, services and names used in this document may have been trademarked by their respective owners. The publication of this information does not imply that any license is granted under any patent or other rights owned by IOT747.

Refer to **Error! Hyperlink reference not valid.** for more information. IOT747® is a trading name for Company Deep Limited.

Change Log

6/1/2021: Draft Version

9/4/2021: Minor Corrections / Typos – Added information on front page

20/7/2021: Clarified Supply configurations. Added Test Points for Fixed Supply

21/7/2021: Simplified Supply configuration – Removed detailed Power States. Deleted references to SPI as only used in IDC707.

20/1/2022: Added certification details and corrected Power Supply connection with correct Pins.